

## Model 205 Pulse Width Modulation Controller

### FEATURES

- precision digitally controlled pulse width modulated output square wave from 1 to 25,000 Hz at 0 to 100 % duty cycle
- duty cycle adjustable in 0.1% steps at all frequency settings
- adjustable duty cycle polarity (normal/reverse)
- configurable start-up of the PWM frequency, duty cycle and operational mode
- PWM output provides low side load control
- Power MOSFET output - PWM output sinks up to 4 amps, fuse protected
- controller operates from same power source that powers the load - an external power source of 7V to 28V DC must be supplied
- built-in user interface for adjustment of frequency and duty cycle (3 switches and LCD)
- integral LCD, 4 line by 20 character, displays frequency, duty cycle, and operational mode
- remote operation via RS-232 interface:
  - set frequency and duty cycle
  - readout out current settings
  - configure controller
- analog input operational modes - control frequency and/or duty cycle output with 2 analog inputs
- external opto-isolated digital input to enable / disable PWM output
- signal outputs
  - 5V level PWM output
  - Unfiltered current output (waveform)
  - Filtered current output (average DC)
- pluggable terminal block I/O connections

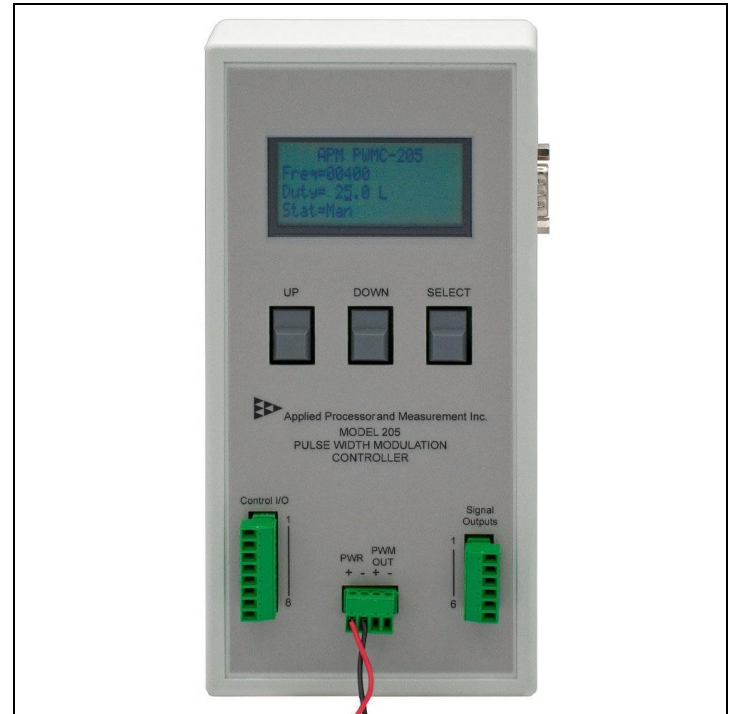

### APPLICATIONS

- engineering development and durability / life testing of any PWM controlled device - valves, actuators, solenoids, relays
- remote control of PWM controlled device
- RS-232 to PWM output signal conditioner
- analog to PWM output signal conditioner

### DESCRIPTION

The Model 205 Pulse Width Modulated Controller from Applied Processor and Measurement, Inc. generates a pulse width modulated variable frequency and duty cycle electrical switching signal. The product is used in many industrial situations where valves, solenoids, actuators, or other magnetic / mechanical elements are applied and / or tested.

The Model 205 PWM Controller contains microcomputer and field programmable gate array (FPGA) digital technology based circuitry allowing for precision generation of the output frequency and duty cycle from a high frequency time base. The internal microcomputer also provides for digital control of the output parameters via the switches on the front panel. Using the switches and the integral LCD, the output frequency and duty cycle may be adjusted digitally, from 1 to 25,000 Hz with a duty cycle resolution of down to 0.1%. The PWM Controller may also be operated via an RS-232 port. Character based commands allow the frequency and duty cycle to be set and displayed. This capability allows the PWM Controller to be computer controlled.

The PWM Controller output is an open drain power MOSFET output providing low side PWM control of the load. A typical connection using the controller is shown in the diagram below. An external power source must be provided. This power source may be used to power both the load and the controller.

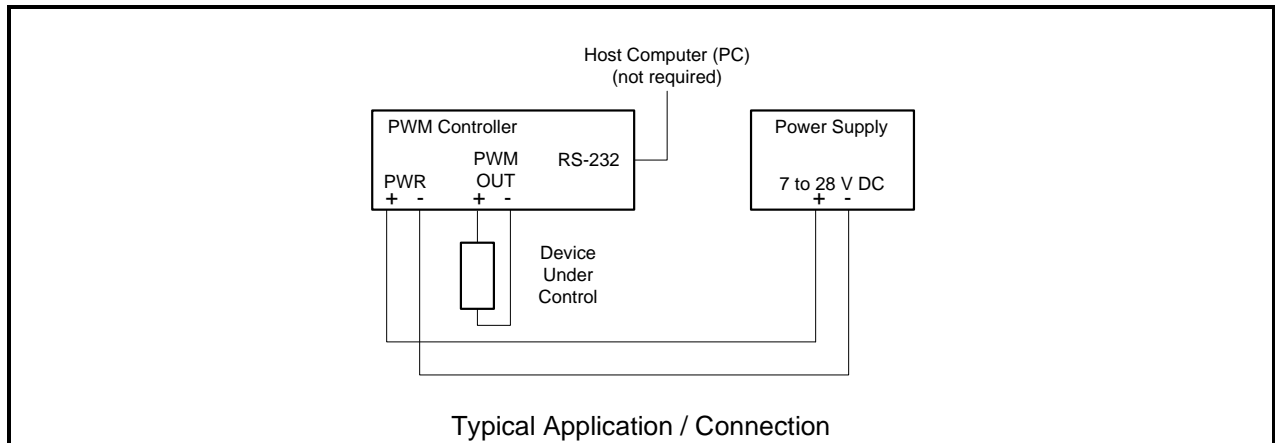

Analog input control modes are also available for the PWM Controller. Using the analog inputs allows the user to control the output frequency and/or duty cycle with analog signals (0 to 5V). An external control system (for example: a PC with data acquisition boards or USB data acquisition equipment, or a PLC) could provide analog outputs to the PWM Controller in order to control a PWM device. In this manner, the PWM Controller is a signal conditioning element for the host computer and/or control system.

The Model 205 also provides 3 signal outputs: a 5V level (low-drive) PWM output for signal generation applications and 2 voltage outputs representative of the PWM output current – an unfiltered waveform of the output current and an average DC voltage output proportional to the PWM current.

A comprehensive User's Manual is provided on our website which describes the operation and application of the PWM controller. Application examples illustrate serial port operation, analog input operation and interfacing, and the use of the PWM Controller as a signal generation element in a control system. A sample PC Windows based program is provided on our website to control the Model 205 from a PC which includes timed sequencing / cycling of duty cycles.

## **SPECIFICATIONS**

- Output: open drain Power MOSFET, 4A continuous, 6A peak
- Frequency: 1 to 1,000 Hz, adjustable in 1 Hz steps, max error < +/- 0.1 Hz  
1,000 to 10,000 Hz, adjustable in 50 Hz steps, max error < +/- 10.0 Hz  
10,000 to 25,000 Hz, adjustable in 100 Hz steps, max error < +/- 50.0 Hz
- Duty Cycle: 0 to 100 %, adjustable in 0.1 % steps  
1 to 100 Hz, max error < +/- 0.01% duty  
100 to 1,000 Hz, max error < +/- 0.02% duty  
1,000 to 10,000 Hz, max error < +/- 0.05% duty  
10,000 to 25,000 Hz, max error < +/- 0.5% duty
- Power: requires 7V to 28V DC, regulated or un-regulated external source  
Controller consumption: 35 mA (typical)  
dual supply configuration required for operating 5V loads (or loads outside 7V to 28V DC)
- 5V Signal Output: 0 to 5V, 15mA max drive
- Current Outputs (unfiltered and average DC): 0.5V output per 1A
- RS-232: TX, RX, GND, 9600 baud, no parity, 8 data bits, 1 stop bit
- Operating Temperature: -20 °C to 70 °C
- Size: 8.66 in. x 4.33 in. x 1.76 in.
- Warranty: 90 days, for manufacturing defects

---

## **ORDER NUMBERS**

PWMC-205                      Model 205 PWM Controller

- standard model 205 PWM Controller
- pushbutton / LCD front-panel interface
- RS232 interface
- single-ended analog inputs, 0 to 5V input

To order options, add –XX suffix(es) to base order number for desired options.

-BD                              Controller Board only

- Model 205 PWM Controller without enclosure, LCD or pushbuttons
- Model 205 operates via RS232 or analog inputs only

-DF                              Differential Analog Inputs

- fully differential analog inputs, over +/- 100V common mode rejection

-10                              Extended Range Analog Inputs

- 0 to 10V inputs, single-ended or differential analog inputs

-FS                              Fast Diode Turn-Off Configuration

-HV                              High DC Voltage Operation

- up to 50V DC power input, PWM output

-PH                              Peak and Hold PWM Operation

- timed peak PWM output, followed by PWM hold, digital input trigger

-CC                              Proportional (Current) Control

- automatic duty cycle control to a constant average current setpoint

Contact APM, Inc. for pricing and availability for Model 205 PWM Controller options.

## **CUSTOM / SEMI-CUSTOM CONTROLLERS**

All standard products from Applied Processor and Measurement, Inc. including the Model 205 PWM Controller are available for customization. The Model 205 can be designed to exacting specifications for your application, reducing cost, changing functionality, or adding features. Contact APM, Inc. via our website for more information, or, call to talk to one of our engineers. APM, Inc has been supplying embedded electronic controls for over 20 years for a wide variety of industrial, automotive and commercial applications.